



US 20170040407A1

(19) **United States**

(12) **Patent Application Publication**
Shin et al.

(10) **Pub. No.: US 2017/0040407 A1**
(43) **Pub. Date: Feb. 9, 2017**

(54) **ORGANIC LIGHT-EMITTING DIODE DISPLAY**

(52) **U.S. Cl.**
CPC *H01L 27/3276* (2013.01); *H01L 27/3262* (2013.01); *H01L 27/3265* (2013.01); *H01L 27/3258* (2013.01); *H01L 51/5203* (2013.01)

(71) Applicant: **Samsung Display Co., Ltd.**, Yongin-si (KR)

(72) Inventors: **Hwang Sup Shin**, Seongnam-si (KR); **Jin Goo Jung**, Seongnam-si (KR)

(57) **ABSTRACT**

An organic light-emitting diode display is disclosed. In one aspect, the display includes a semiconductor layer including a driving channel, a first gate insulating layer at least partially covering the semiconductor layer, and a first driving gate electrode formed over the first gate insulating layer and overlapping the driving. A second gate insulating layer at least partially covers the first driving gate electrode. The display also includes a second driving gate electrode formed over the second gate insulating layer and overlapping the first driving gate electrode, an interlayer insulating layer at least partially covering the second driving gate electrode, a driving voltage line formed over the interlayer insulating layer and overlapping the second driving gate electrode, and a connector formed over the interlayer insulating layer and connected to the first and second driving gate electrodes.

(21) Appl. No.: **15/228,974**

(22) Filed: **Aug. 4, 2016**

(30) **Foreign Application Priority Data**

Aug. 6, 2015 (KR) 10-2015-0111262

Publication Classification

(51) **Int. Cl.**
H01L 27/32 (2006.01)
H01L 51/52 (2006.01)

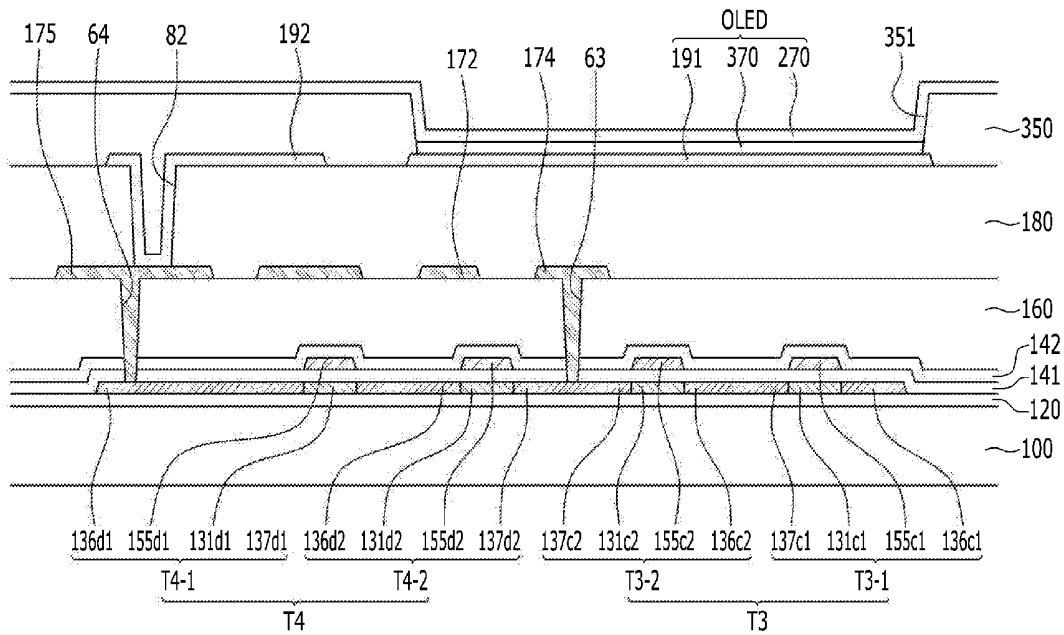

FIG. 1

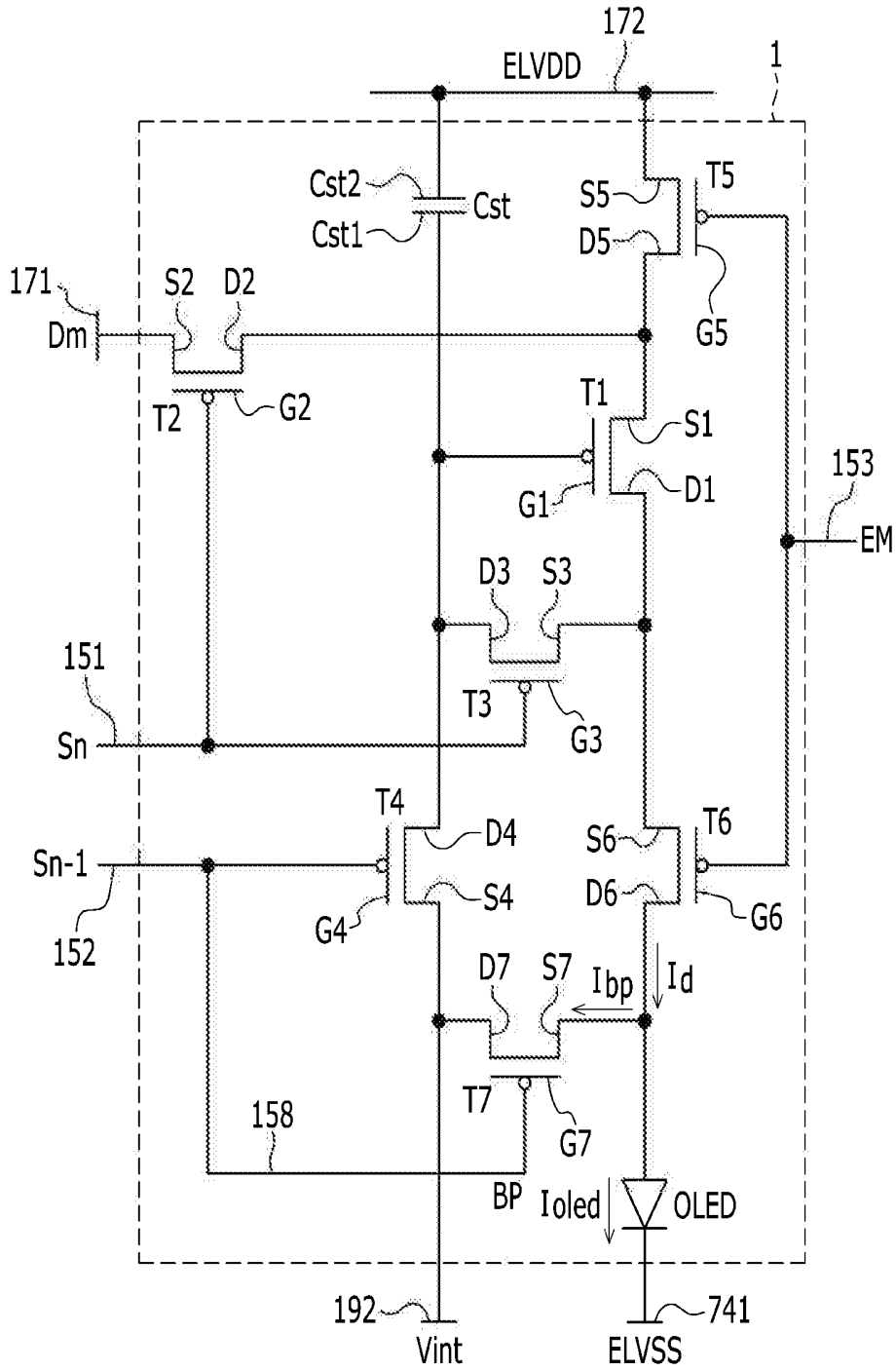

FIG. 2

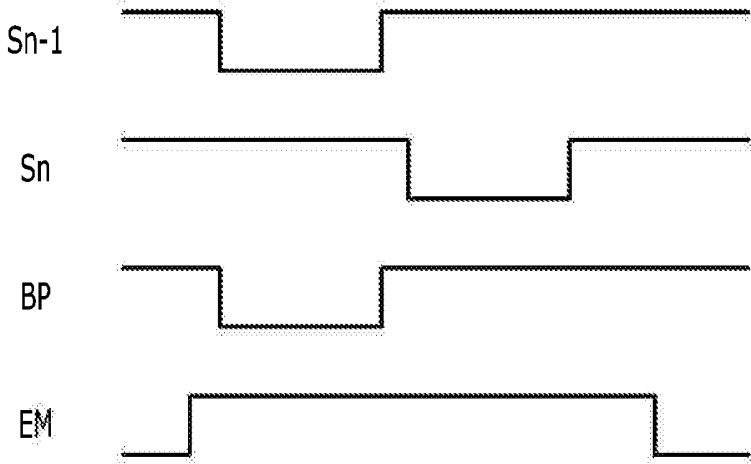

FIG. 4

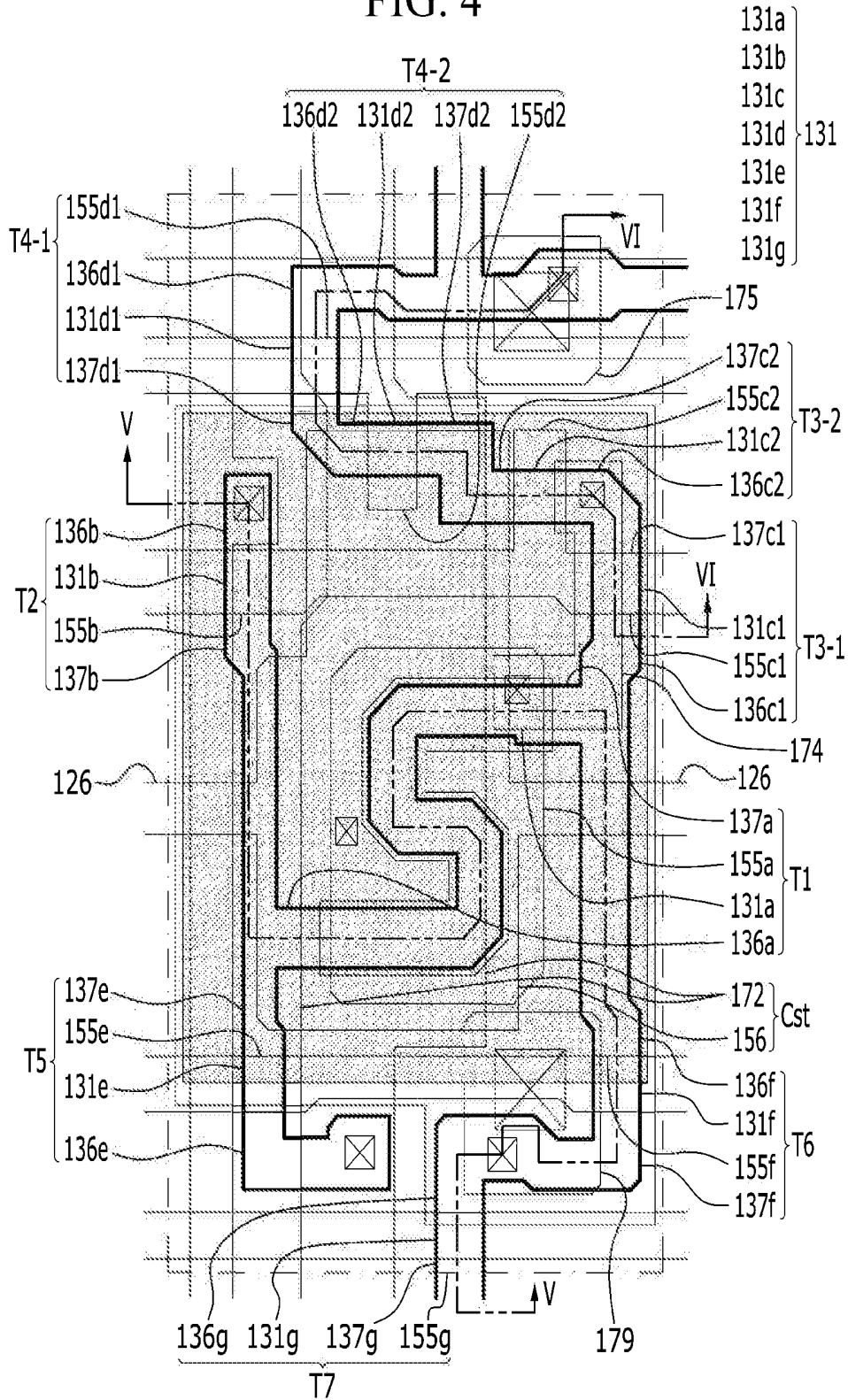

FIG. 5

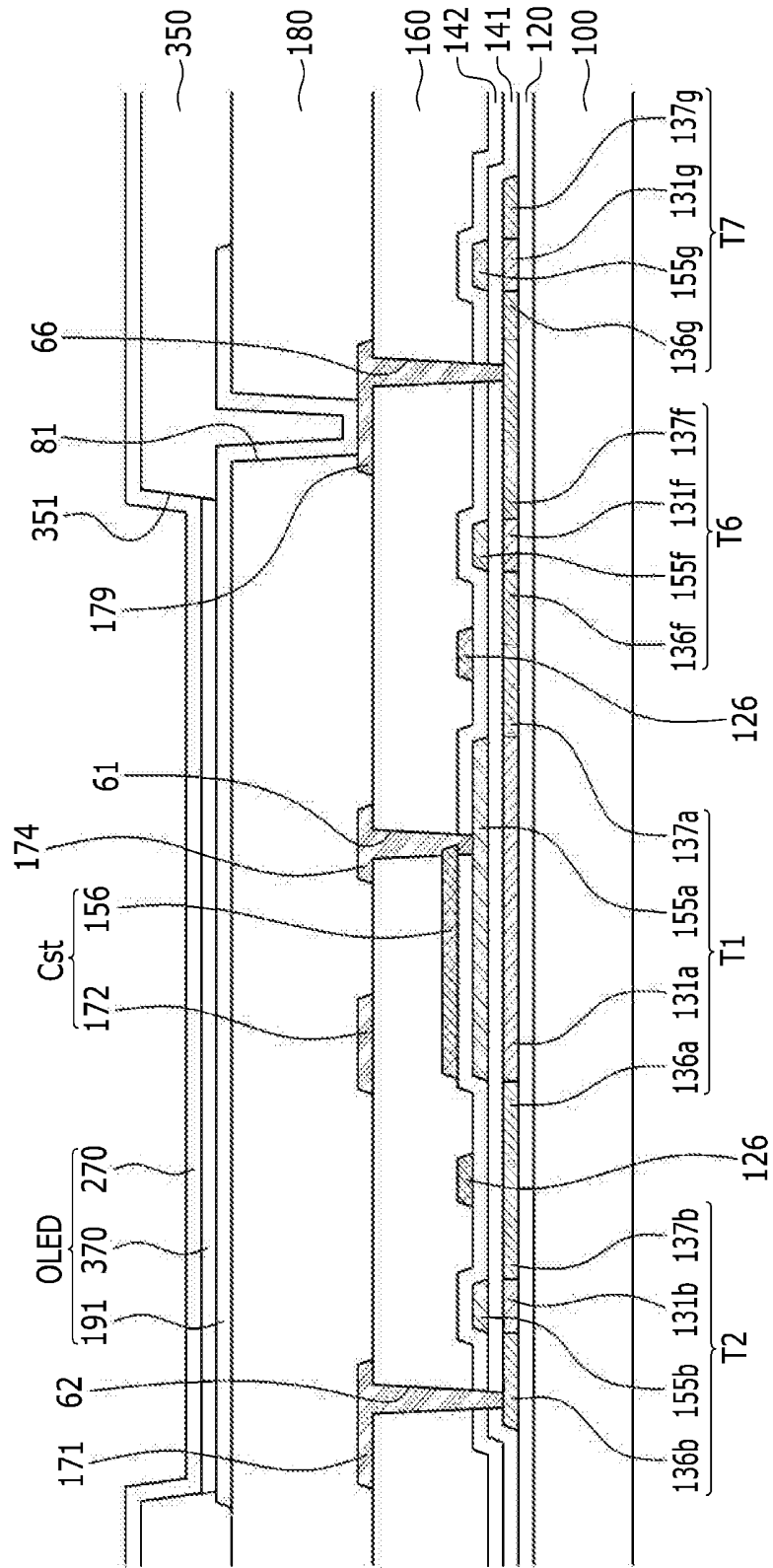
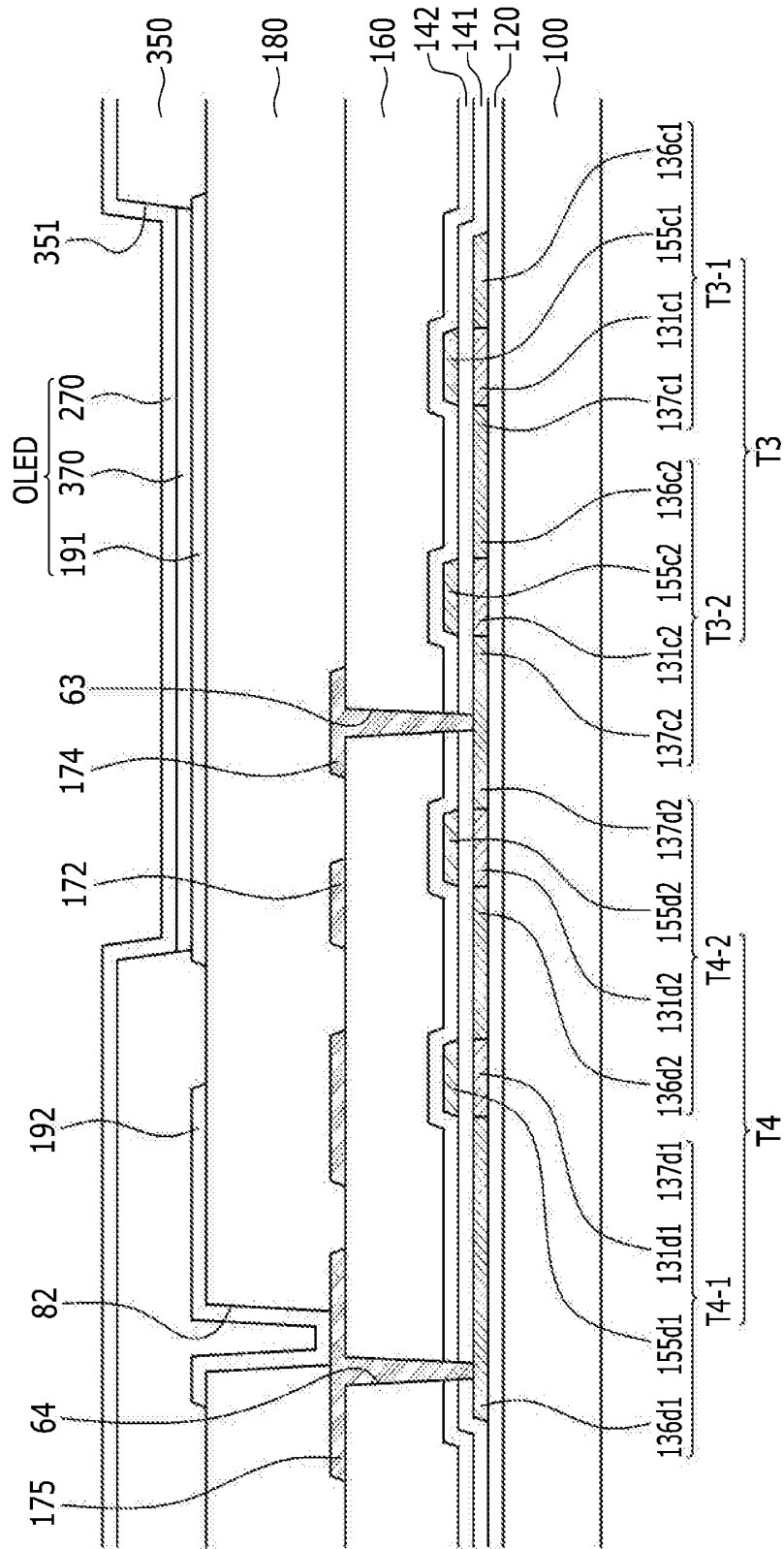

FIG. 6



ORGANIC LIGHT-EMITTING DIODE DISPLAY

INCORPORATION BY REFERENCE TO ANY PRIORITY APPLICATIONS

[0001] This application claims priority to and the benefit of Korean Patent Application No. 10-2015-0111262 filed in the Korean Intellectual Property Office on Aug. 6, 2015, the entire contents of which are incorporated herein by reference.

BACKGROUND

[0002] Field

[0003] The described technology generally relates to an organic light-emitting diode (OLED) display.

[0004] Description of the Related Technology

[0005] An OLED display includes two electrodes and an interposed organic emission layer. Light is emitted by combining electrons injected from a cathode, which is one electrode, with holes injected from an anode, which is the other electrode, in the organic emission layer to generate excitons, allowing the excitons to release energy.

[0006] Such an OLED display includes a matrix of pixels including an OLED and multiple transistors and storage capacitors that are formed in a circuit to drive the OLED in each pixel (or pixel circuit). These transistors and storage capacitors include multiple wires, including a semiconductor, a gate line, a data line, and the like.

[0007] The higher the resolution is, the smaller the pixel size is, resulting in a smaller margin for error in the processing steps. Accordingly, a change in the widths of wires, the size of a contact hole, or an alignment error can cause defects. That is, as the resolution becomes higher, wires actually formed in a product can be formed thinner than pre-designed wires, a contact hole actually formed in the product can be formed larger than a pre-designed contact hole, and an interlayer alignment error can tend to more easily increase.

[0008] Accordingly, high resolution makes it difficult to secure the capacitance of the storage capacitor.

[0009] The above information disclosed in this Background section is only to enhance the understanding of the background of the described technology and therefore it may contain information that does not constitute the prior art that is already known in this country to a person of ordinary skill in the art.

SUMMARY OF CERTAIN INVENTIVE ASPECTS

[0010] One inventive aspect relates to an OLED display with a high resolution structure having the advantage of increasing capacitance of a storage capacitor.

[0011] Another aspect is an OLED display including: a substrate; a semiconductor including a driving channel on the substrate; a first gate insulating layer covering the semiconductor; a first driving gate electrode on the first gate insulating layer and overlapping the driving channel; a second gate insulating layer covering the first driving gate electrode; a second driving gate electrode on the second gate insulating layer and partially overlapping the first driving gate electrode; an interlayer insulating layer covering the second driving gate electrode; a driving voltage line on the interlayer insulating layer and overlapping the second driv-

ing gate electrode; and a connecting member on the interlayer insulating layer and electrically connected to the first and second driving gate electrodes.

[0012] The interlayer insulating layer and the second gate insulating layer can include a contact hole that electrically couples the connecting member with the first driving gate electrode and the second driving gate electrode.

[0013] The contact hole can expose one end of the second driving gate electrode and a part of a surface of the first driving gate electrode.

[0014] The OLED display can further include a storage capacitor which comprises: a first storage electrode on the second gate insulating layer and overlapping the driving channel; and a second storage electrode overlapping the first storage electrode while interposing the interlayer insulating layer therebetween.

[0015] The first storage electrode can be the second driving gate electrode, and the second storage electrode can be the driving voltage line.

[0016] The OLED display can further include: a scan line at a same layer as the first driving gate electrode and transmitting a scan signal; and a light emission control line disposed at a same layer as the first driving gate electrode, extending parallel to the scan line, and transmitting a light emission control signal.

[0017] The first driving gate electrode can be positioned between the scan line and the light emission control line.

[0018] A driving voltage ELVDD can be transmitted to the driving voltage line.

[0019] A gate voltage can be transmitted to the first driving gate electrode and the second driving gate electrode.

[0020] The second driving gate electrode can have a larger area than the first driving gate electrode.

[0021] The semiconductor can further include a switching channel, a compensation channel, an initialization channel, an operation control channel, a light emission control channel, and a bypass channel.

[0022] The OLED display can further include a passivation layer covering the interlayer insulating layer. The OLED includes a pixel electrode on the passivation layer, an organic emission layer on the pixel electrode, and a common electrode on the organic emission layer.

[0023] Another aspect is an organic light-emitting diode (OLED) display comprising: a substrate; a semiconductor layer including a driving channel formed over the substrate; a first gate insulating layer at least partially covering the semiconductor layer; a first driving gate electrode formed over the first gate insulating layer and overlapping the driving channel in the depth dimension of the OLED display; a second gate insulating layer at least partially covering the first driving gate electrode; a second driving gate electrode formed over the second gate insulating layer and overlapping the first driving gate electrode in the depth dimension of the OLED display; an interlayer insulating layer at least partially covering the second driving gate electrode; a driving voltage line formed over the interlayer insulating layer and overlapping the second driving gate electrode in the depth dimension of the OLED display; and a connector formed over the interlayer insulating layer and connected to the first and second driving gate electrodes.

[0024] In the above OLED display, the interlayer insulating layer and the second gate insulating layer include a contact hole through which the connector passes to connect the first and second driving gate electrodes.

[0025] In the above OLED display, the contact hole is connected to one lateral end of the second driving gate electrode and a portion of a surface of the first driving gate electrode.

[0026] The above OLED display further comprises a storage capacitor including: a first storage electrode formed over the second gate insulating layer and overlapping the driving channel in the depth dimension of the OLED display; and a second storage electrode overlapping the first storage electrode in the depth dimension of the OLED display, wherein the interlayer insulating layer is interposed between the first and second storage electrodes.

[0027] In the above OLED display, the first storage electrode is configured to function as the second driving gate electrode, wherein the second storage electrode is configured to function as a portion of the driving voltage line.

[0028] The above OLED display further comprising: a scan line formed on the same layer as the first driving gate electrode and configured to transfer a scan signal; and a light emission control line formed on the same layer as the first driving gate electrode and extending parallel to the scan line, wherein the light emission control line is configured to transfer a light emission control signal.

[0029] In the above OLED display, the first driving gate electrode is positioned between the scan line and the light emission control line.

[0030] In the above OLED display, the driving voltage line is configured to transfer a driving voltage.

[0031] In the above OLED display, each of the first and second driving gate electrode is configured to receive a gate voltage via the connector.

[0032] In the above OLED display, the second driving gate electrode has an area larger than that of the first driving gate electrode.

[0033] In the above OLED display, the semiconductor layer further includes a switching channel, a compensation channel, an initialization channel, an operation control channel, a light emission control channel, and a bypass channel.

[0034] The above OLED display further comprises a passivation layer covering the interlayer insulating layer, wherein the OLED includes a pixel electrode formed over the passivation layer, an organic emission layer formed over the pixel electrode, and a common electrode formed over the organic emission layer.

[0035] Another aspect is an organic light-emitting diode (OLED) display comprising: a first gate insulating layer; a first driving gate electrode formed over the first gate insulating layer; a second gate insulating layer formed over the first driving gate electrode; a second driving gate electrode formed over the second gate insulating layer; an interlayer insulating layer formed over the second driving gate electrode and having a contact hole formed therein; and a connector passing through the contact hole and connecting the first and second driving gate electrodes so as to form a conductive path between the electrodes.

[0036] In the above OLED display, the connector extends to and contacts the interlayer insulating layer.

[0037] The above OLED display further comprises a driving voltage line configured to transfer a driving voltage, wherein the second driving gate electrode and the driving voltage line form a storage capacitor.

[0038] In the above OLED display, the first driving gate electrode has a width that is larger than that of the second driving gate electrode.

[0039] In the above OLED display, a bottom surface of the contact hole is connected to a top surface of the first driving gate electrode.

[0040] In the above OLED display, the second driving gate electrode has an end that penetrates a side surface of the contact hole.

[0041] The above OLED display further comprises a storage line formed on the second gate insulating layer, wherein the second driving gate electrode is an extension of the storage line.

[0042] In the above OLED display, the interlayer insulating layer is thicker than a combined thickness of the first and second driving gate electrodes.

[0043] According to at least one of the disclosed embodiments, capacitance of the storage capacitor can be increased in a high resolution structure.

BRIEF DESCRIPTION OF THE DRAWINGS

[0044] FIG. 1 is an equivalent circuit diagram of one pixel of an organic light emitting diode (OLED) display according to an exemplary embodiment.

[0045] FIG. 2 is a timing diagram of a signal applied to one pixel of the OLED display according to the exemplary embodiment.

[0046] FIG. 3 schematically illustrates a plurality of transistors and capacitors of the OLED display according to the exemplary embodiment.

[0047] FIG. 4 is a detailed layout view of FIG. 3.

[0048] FIG. 5 is a cross-sectional view of the OLED display of FIG. 4 taken along the line V-V.

[0049] FIG. 6 is a cross-sectional view of the OLED display of FIG. 4 taken along the line VI-VI.

DETAILED DESCRIPTION OF CERTAIN INVENTIVE EMBODIMENTS

[0050] The described technology will be described more fully hereinafter with reference to the accompanying drawings, in which exemplary embodiments are shown. As those skilled in the art would realize, the described embodiments can be modified in various different ways, all without departing from the spirit or scope of the described technology.

[0051] Parts that are irrelevant to the description will be omitted to clearly describe the described technology, and the same or similar constituent elements will be designated by the same reference numerals throughout the specification.

[0052] Further, in the drawings, the size and thickness of each element are arbitrarily illustrated for ease of description, and the described technology is not necessarily limited to those illustrated in the drawings.

[0053] In the drawings, the thickness of layers, films, panels, regions, etc., are exaggerated for clarity. In the drawings, for ease of description, the thicknesses of some layers and regions are exaggerated. It will be understood that when an element such as a layer, film, region, or substrate is referred to as being "on" another element, it can be directly on the other element or intervening elements can also be present.

[0054] In addition, unless explicitly described to the contrary, the word "comprise" and variations such as "comprises" or "comprising", will be understood to imply the inclusion of stated elements, but not the exclusion of any other elements. Further, throughout the specification, the

word “on” means positioning on or below the object portion, and does not necessarily mean positioning on the upper side of the object portion based on a gravitational direction.

[0055] Further, throughout the specification, the word “on a plane” means viewing a target portion from the top, and the word “on a cross section” means viewing a cross section formed by vertically cutting a target portion from the side. In this disclosure, the term “substantially” includes the meanings of completely, almost completely or to any significant degree under some applications and in accordance with those skilled in the art. Moreover, “formed, disposed or positioned over” can also mean “formed, disposed or positioned on.” The term “connected” includes an electrical connection.

[0056] Now, an OLED display according to an exemplary embodiment will be described in detail with reference to FIGS. 1 to 5.

[0057] FIG. 1 is an equivalent circuit diagram of one pixel of an OLED display according to an exemplary embodiment.

[0058] As shown in FIG. 1, one pixel 1 of the OLED display according to the exemplary embodiment includes: a plurality of signal lines 151, 152, 153, 158, 171, 172, and 192; a plurality of transistors T1, T2, T3, T4, T5, T6, and T7 that are connected to the plurality of signal lines; a storage capacitor Cst; and an OLED.

[0059] The transistors T1, T2, T3, T4, T5, T6, and T7 include a driving transistor T1, a switching transistor T2, a compensation transistor T3, an initialization transistor T4, an operation control transistor T5, a light emission control transistor T6, and a bypass transistor T7.

[0060] The signal lines 151, 152, 153, 158, 171, 172, and 192 include a scan line 151 for transmitting a scan signal Sn, a previous scan line 152 for transmitting a previous scan signal Sn-1 to the initialization transistor T4, a light emission control line 153 for transmitting a light emission control signal EM to the operation control transistor T5 and the light emission control transistor T6, a bypass control line 158 for transmitting a bypass signal BP to the bypass transistor T7, a data line 171 crossing the scan line 151 and transmitting a data signal Dm, a driving voltage line 172 transmitting a driving voltage ELVDD and disposed nearly parallel to the data line 171, and an initialization voltage line 192 for transmitting an initialization voltage Vint initializing the driving transistor T1.

[0061] A gate electrode G1 of the driving transistor T1 is connected to one end Cst1 of the storage capacitor Cst, a source electrode S1 of the driving transistor T1 is connected to the driving voltage line 172 via the operation control transistor T5, and a drain electrode D1 of the driving transistor T1 is electrically connected to an anode of the OLED via the light emission control transistor T6. The driving transistor T1 receives a data signal Dm according to a switching operation of the switching transistor T2, and provides a driving current Id to the OLED.

[0062] A gate electrode G2 of the switching transistor T2 is connected to the scan line 151, a source electrode S2 of the switching transistor T2 is connected to the data line 171, and a drain electrode D2 of the switching transistor T2 is connected to the driving voltage line 172 via the operation control transistor T5 while being connected to the source electrode S1 of the driving transistor T1. The switching transistor T2 is turned on by the scan signal Sn transmitted via the scan line 151, and performs the switching operation

of transmitting the data signal Dm transmitted via the data line 171 to the source electrode S1 of the driving transistor T1.

[0063] A gate electrode G3 of the compensation transistor T3 is connected to the scan line 151, a source electrode S3 of the compensation transistor T3 is connected to the anode of the OLED via the light emission control transistor T6 while being connected to the drain electrode D1 of the driving transistor T1, and a drain electrode D3 of the compensation transistor T3 is connected to a drain electrode D4 of the initialization transistor T4, one end Cst1 of the storage capacitor Cst, and the gate electrode G1 of the driving transistor T1. The compensation transistor T3 is turned on by the scan signal Sn transmitted via the scan line 151, and couples the gate electrode G1 to the drain electrode D1 of the driving transistor T1, such that the driving transistor T1 is diode-connected.

[0064] A gate electrode G4 of the initialization transistor T4 is connected to the previous scan line 152, a source electrode S4 of the initialization transistor T4 is connected to the initialization voltage line 192, and the drain electrode D4 of the initialization transistor T4 is connected to one end Cst1 of the storage capacitor Cst and the gate electrode G1 of the driving transistor T1 via the drain electrode D3 of the compensation transistor T3. The initialization transistor T4 is turned on by the previous scan signal Sn-1 transmitted via the previous scan line 152, and performs an initialization operation of transmitting the initialization voltage Vint to the gate electrode G1 of the driving transistor T1 to initialize a gate voltage of the gate electrode G1 of the driving transistor T1.

[0065] A gate electrode G5 of the operation control transistor T5 is connected to the light emission control line 153, a source electrode S5 of the operation control transistor T5 is connected to the driving voltage line 172, and a drain electrode D5 of the operation control transistor T5 is connected to the source electrode S1 of the driving transistor T1 and the drain electrode S2 of the switching transistor T2.

[0066] A gate electrode G6 of the light emission control transistor T6 is connected to the light emission control line 153, a source electrode S6 of the light emission control transistor T6 is connected to the drain electrode D1 of the driving transistor T1 and the source electrode S3 of the compensation transistor T3, and a drain electrode D6 of the light emission control transistor T6 is electrically connected to the anode of the OLED. The operation control transistor T5 and the light emission control transistor T6 are substantially simultaneously (or concurrently) turned on by the light emission control signal EM that is transmitted via the light emission control line 153, such that the driving voltage ELVDD is compensated by the diode-connected driving transistor T1 to be transmitted to the OLED.

[0067] A gate electrode G7 of the bypass transistor T7 is connected to the bypass control line 158, a source electrode S7 of the bypass transistor T7 is connected to both the drain electrode D6 of the light emission control transistor T6 and the anode of the OLED, and a drain electrode D7 of the bypass transistor T7 is connected to both the initialization voltage line 192 and the source electrode S4 of the initialization thin film transistor T4. In this case, since the bypass control line 158 is connected to the previous scan line 152, the bypass signal BP is the same as the previous scan signal Sn-1.

[0068] The other end Cst2 of the storage capacitor Cst is connected to the driving voltage line 172, and a cathode of the OLED is connected to a common voltage line 741 for transmitting a common voltage ELVSS.

[0069] Meanwhile, in the current exemplary embodiment, a 7Tr-1cap (7 Transistors and 1 capacitor) structure including the bypass transistor T7 is illustrated, but the described technology is not limited thereto, and the number of transistors and the number of capacitors can be changed in various ways.

[0070] An operation of one pixel of an OLED display according to an exemplary embodiment will now be described in detail with reference to FIG. 2.

[0071] FIG. 2 is a timing diagram of a signal applied to one pixel of the OLED display according to the exemplary embodiment.

[0072] As shown in FIG. 2, first, for an initialization period, a low-level previous scan signal Sn-1 is supplied via a previous scan line 152. Then, an initialization transistor T4 is turned on in response to the low-level previous scan signal Sn-1, an initialization voltage Vint from an initialization voltage line 192 is coupled to a gate electrode G1 of a driving transistor T1 via the initialization transistor T4, and a driving transistor T1 is initialized by the initialization voltage Vint.

[0073] Subsequently, for a data programming period, a low-level scan signal Sn is supplied via a scan line 151. Then, in response to the low-level scan signal Sn, a switching transistor T2 and a compensation transistor T3 are turned on. In this case, the driving transistor T1 is diode-connected by the turned on compensation transistor T3, and is forward biased.

[0074] Then, a compensation voltage $Dm+V_{th}$ (V_{th} is a negative value), i.e., a data signal Dm supplied from a data line 171 that is reduced by a threshold voltage V_{th} of the driving transistor T1, is applied to a gate electrode G1 of the driving transistor T1. A driving voltage ELVDD and the compensation voltage $Dm+V_{th}$ are applied to opposite ends of a storage capacitor Cst, and an amount of charge corresponding to a voltage difference between the opposite ends is stored in the storage capacitor Cst.

[0075] Subsequently, for an emission period, a light emission control signal EM supplied from a light emission control line 153 is changed from a high level to a low level. Then, for the emission period, an operation control transistor T5 and a light emission control transistor T6 are turned on by the low-level light emission control signal EM.

[0076] Then, a driving current Id associated with a voltage difference between the gate voltage of the gate electrode G1 of the driving transistor T1 and the driving voltage ELVDD is generated, and the driving current Id is supplied to the OLED via the light emission control transistor T6. For the emission period, a gate-source voltage V_{gs} of the driving transistor T1 is maintained at $(Dm+V_{th})-ELVDD$ by the storage capacitor Cst, and according to a current-voltage relationship of the driving transistor T1, the driving current Id is proportional to the square of a value calculated by subtracting the threshold voltage of the driving transistor T1 from the source-gate voltage, i.e., $(Dm-ELVDD)^2$. Accordingly, the driving current Id is determined regardless of the threshold voltage V_{th} of the driving transistor T1.

[0077] In this case, a bypass transistor T7 receives a bypass signal BP from a bypass control line 158. Since the bypass signal BP is a predetermined level of voltage which

can always turn the bypass transistor T7 off, the bypass transistor T7 is always turned off by receiving the level of voltage for turning the transistor off via the gate electrode G7, and the bypass transistor T7 is always turned off and allows the driving current Id to partially flow out as a bypass current Ibp via the bypass transistor T7 when in a turned-off state.

[0078] Even when a minimum amount of current of the driving transistor T1 representing a black image flows as a driving current, the black image is not properly displayed if the OLED emits light. Accordingly, the bypass transistor T7 of the OLED display according to the current exemplary embodiment can distribute a part of the minimum amount of current of the driving transistor T1 to current paths other than the current path toward the OLED as the bypass current Ibp. Here, the minimum amount of current of the driving transistor T1 means a current with the driving transistor T1 turned off since the gate-source voltage V_{gs} of the driving transistor T1 is smaller than the threshold voltage V_{th} . The minimum amount of driving current (e.g., current of less than about 10 pA) with the driving transistor T1 turned off is supplied to the OLED such that it is represented as a black image. When the minimum amount of driving current representing the black image flows, bypassing the bypass current Ibp has a significant effect, whereas the bypass current Ibp has virtually no effect at all if a large amount of driving current representing an image such as an ordinary image or a white image flows. Accordingly, a light emission current holed of the OLED, which is reduced by an amount of the bypass current Ibp flowing out from the driving current Id via the bypass transistor T7 when the driving current representing the black image flows, has a minimum amount of current at a level in which the black image is sure to be expressed. Accordingly, an accurate black image can be realized using the bypass transistor T7 to improve a contrast ratio. In FIG. 2, the bypass signal BP is the same as the previous scan signal Sn-1, but it is not necessarily limited thereto.

[0079] An OLED display according to an exemplary embodiment to which the above-described structure is applied will now be described in detail with reference to FIGS. 3 to 6.

[0080] FIG. 3 schematically illustrates a plurality of transistors and capacitors of the OLED display according to the exemplary embodiment. FIG. 4 is a detailed layout view of FIG. 3. FIG. 5 is a cross-sectional view of the OLED display of FIG. 3 taken along the line V-V. and FIG. 6 is a cross-sectional view of the OLED display of FIG. 3 taken along the line VI-VI.

[0081] A detailed planar structure of the OLED display according to the exemplary embodiment will be described first with reference to FIGS. 3 and 4, and a detailed cross-sectional structure will be described with reference to FIGS. 5 and 6.

[0082] First, as shown in FIG. 3, the OLED display according to the current exemplary embodiment includes a scan line 151, a previous scan line 152, a light emission control line 153, and a bypass control line 158, via which a scan signal Sn, a previous scan signal Sn-1, a light emission control signal EM, and bypass signal BP are respectively applied and which are formed in a row direction. In addition, the OLED display includes a data line 171 and a driving voltage line 172 that cross the scan line 151, the previous scan line 152, the light emission control line 153, and the

bypass control line **158**, and that respectively apply a data signal *Dm* and a driving voltage ELVDD to a pixel **1**. An initialization voltage *Vint* is transmitted from an initialization voltage line **192** to a compensation transistor **T3** via an initialization transistor **T4**.

[0083] In addition, a driving transistor **T1**, a switching transistor **T2**, the compensation transistor **T3**, the initialization transistor **T4**, an operation control transistor **T5**, a light emission control transistor **T6**, a bypass transistor **T7**, a storage capacitor *Cst*, and an OLED are formed in pixel **1**. The OLED includes a pixel electrode **191**, an organic emission layer **370**, and a common electrode **270**. In this case, the compensation transistor **T3** and the initialization transistor **T4** are configured as a transistor with a dual gate structure so as to prevent current leakage.

[0084] A channel of each of the driving transistor **T1**, the switching transistor **T2**, the compensation transistor **T3**, the initialization transistor **T4**, the operation control transistor **T5**, the light emission control transistor **T6**, and the bypass transistor **T7** is formed inside a semiconductor **130** that is connected, and the semiconductor **130** can be bent to be formed in various shapes. The semiconductor **130** can be formed of a polysilicon semiconductor material or an oxide semiconductor material. The oxide semiconductor material can be any one of the oxides based on titanium (Ti), hafnium (Hf), zirconium (Zr), aluminum (Al), tantalum (Ta), germanium (Ge), zinc (Zn), gallium (Ga), tin (Sn), or indium (In), and composite oxides thereof, such as an indium-gallium-zinc oxide (InGaZnO₄), an indium-zinc-oxide (Zn—In—O), a zinc-tin oxide (Zn—Sn—O), an indium-gallium oxide (In—Ga—O), an indium-tin oxide (In—Sn—O), an indium-zirconium-oxide (In—Zr—O), an indium-zirconium-zinc oxide (In—Zr—Zn—O), an indium-zirconium-tin oxide (In—Zr—Sn—O), an indium-zirconium-gallium oxide (In—Zr—Ga—O), an indium-aluminum oxide (In—Al—O), an indium-zinc-aluminum oxide (In—Zn—Al—O), an indium-tin-aluminum oxide (In—Sn—Al—O), an indium-aluminum-gallium oxide (In—Al—Ga—O), an indium-tantalum oxide (In—Ta—O), an indium-tantalum-zinc oxide (In—Ta—Zn—O), an indium-tantalum-tin oxide (In—Ta—Sn—O), an indium-tantalum-gallium oxide (In—Ta—Ga—O), an indium-germanium oxide (In—Ge—O), an indium-germanium-zinc oxide (In—Ge—Zn—O), an indium-germanium-tin oxide (In—Ge—Sn—O), an indium-germanium-gallium oxide (In—Ge—Ga—O), an titanium-indium-zinc oxide (Ti—In—Zn—O), and a hafnium-indium-zinc oxide (Hf—In—Zn—O). When the semiconductor **130** is formed of an oxide semiconductor material, an additional passivation layer can be added to protect the oxide semiconductor, which is vulnerable to an external environment such as high temperature and the like.

[0085] The semiconductor **130** includes a channel that is channel-doped with an N-type impurity or a P-type impurity, and source and drain doping regions that are formed at opposite sides of the channel and are doped at higher doping concentrations compared to that of the doping impurity doped in the channel. In the current exemplary embodiment, the source doping region and the drain doping region respectively correspond to a source electrode and a drain electrode. The source and drain electrodes formed in the semiconductor **130** can be formed by doping only corresponding regions. In addition, in the semiconductor **130**, regions between source and drain electrodes of different

transistors can also be doped, such that the source and drain electrodes are electrically coupled.

[0086] As shown in FIG. 3, a channel **131** includes a driving channel **131a** formed in the driving transistor **T1**, a switching channel **131b** formed in the switching transistor **T2**, a compensation channel **131c** formed in the compensation transistor **T3**, an initialization channel **131d** formed in the initialization transistor **T4**, an operation control channel **131e** formed in the operation control transistor **T5**, a light emission control channel **131f** formed in the light emission control transistor **T6**, and a bypass channel **131g** formed in the bypass transistor **T7**.

[0087] The driving transistor **T1** includes the driving channel **131a**, a first driving gate electrode **155a**, a driving source electrode **136a**, and a driving drain electrode **137a**. The driving channel **131a** is curved, and can have a meandering shape or a zigzag shape. As described above, since the driving channel **131a** is curvedly formed, the driving channel **131a** is formed to be long within a narrow space. Accordingly, a driving range of a gate voltage *Vg* applied to the first driving gate electrode **155a** can be widened by the driving channel **131a** that is formed to be long. Since the driving range of the gate voltage *Vg* is widened, a gray level of light emitted from the OLED can be more precisely controlled by changing the gate voltage *Vg*, thereby enhancing resolution and display quality of the OLED display. Various exemplary embodiments such as a 'reverse S', 'S', 'M', and 'W' can be implemented by modifying the shape of the driving channel **131a** in different ways.

[0088] The first driving gate electrode **155a** overlaps the driving channel **131a**, and the driving source electrode **136a** and the driving drain electrode **137a** are respectively formed adjacent to opposite sides of the driving channel **131a**. The first driving gate electrode **155a** is connected to a first connecting member (or first connector) **174** via a contact hole **61**.

[0089] The switching transistor **T2** includes the switching channel **131b**, a switching gate electrode **155b**, a switching source electrode **136b**, and a switching drain electrode **137b**. The switching gate electrode **155b** corresponding a downwardly extending part of the scan line **151** overlaps the switching channel **131b**, and the switching source electrode **136b** and the switching drain electrode **137b** are respectively formed adjacent to opposite sides of the switching channel **131b**. The switching source electrode **136b** is connected to the data line **171** via a contact hole **62**.

[0090] The compensation transistor **T3** is formed as a pair to prevent current leakage, and includes a first compensation transistor **T3-1** and a second compensation transistor **T3-2** that are adjacent to each other. The first compensation transistor **T3-1** is positioned around the scan line **151**, and the second compensation transistor **T3-2** is positioned around a protruding portion of the scan line **151**. The first compensation transistor **T3-1** includes a first compensation channel **131c1**, a first compensation gate electrode **155c1**, a first compensation source electrode **136c1**, and a first compensation drain electrode **137c1**, and the second compensation transistor **T3-2** includes a second compensation channel **131c2**, a second compensation gate electrode **155c2**, a second compensation source electrode **136c2**, and a second compensation drain electrode **137c2**.

[0091] The first compensation gate electrode **155c1**, which is a part of the scan line **151**, overlaps the first compensation channel **131c1**, and the first compensation source electrode

136c1 and the first compensation drain electrode **137c1** are respectively formed adjacent to opposite sides of the first compensation channel **131c1**. The first compensation source electrode **136c1** is connected to a light emission control source electrode **136f** and the driving drain electrode **137a**, and the first compensation drain electrode **137c1** is connected to the second compensation source electrode **136c2**.

[0092] The second compensation gate electrode **155c2**, which is an upwardly protruding part of the scan line **151**, overlaps the second compensation channel **131c2**, and the second compensation source electrode **136c2** and the second compensation drain electrode **137c2** are respectively formed adjacent to opposite sides of the second compensation channel **131c2**. The second compensation drain electrode **137c2** is connected to the first connecting member **174** via a contact hole **63**.

[0093] The initialization transistor **T4** is formed as a pair to prevent current leakage, and includes a first initialization transistor **T4-1** and a second initialization transistor **T4-2** that are adjacent to each other. The first initialization transistor **T4-1** is positioned around the previous scan line **152**, and the second initialization transistor **T4-2** is positioned around a protruding portion of the previous scan line **152**. The first initialization transistor **T4-1** includes a first initialization channel **131d1**, a first initialization gate electrode **155d1**, a first initialization source electrode **136d1**, and a first initialization drain electrode **137d1**, and the second initialization transistor **T4-2** includes a second initialization channel **131d2**, a second initialization gate electrode **155d2**, a second initialization source electrode **136d2**, and a second initialization drain electrode **137d2**.

[0094] The first initialization gate electrode **155d1**, which is a part of the previous scan line **152**, overlaps the first initialization channel **131d1**, and is respectively formed adjacent to opposite sides of the first initialization channel **131d1**. The first initialization source electrode **136d1** is connected to a second connecting member (or second connector) **175** via a contact hole **64**, and the first initialization drain electrode **137d1** is connected to the second initialization source electrode **136d2**.

[0095] The second initialization gate electrode **155d2**, which is a downwardly protruding part of the previous scan line **152**, overlaps the second initialization channel **131d2**, and the second initialization source electrode **136d2** and the second initialization drain electrode **137d2** are respectively formed adjacent to opposite sides of the second initialization channel **131c2**. The second initialization drain electrode **137d2** is connected to the first connecting member **174** via the contact hole **63**.

[0096] As such, by forming the compensation transistor **T3** as the pair of first and second compensation transistors **T3-1** and **T3-2** and the initialization transistor **T4** as the pair of first and second initialization transistors **T4-1** and **T4-2**, moving paths of electrons via the channels **131c1**, **131c2**, **131d1**, and **131d2** can be blocked when turned off, thereby effectively preventing current leakage from being generated.

[0097] The operation control transistor **T5** includes the operation control channel **131e**, an operation control gate electrode **155e**, an operation control source electrode **136e**, and an operation control drain electrode **137e**. The operation control gate electrode **155e**, which is a part of the light emission control line **153**, overlaps the operation control channel **131e**, and the operation control source electrode **136e** and the operation control drain electrode **137e** are

respectively formed adjacent to opposite sides of the operation control channel **131e**. The operation control source electrode **136e** is connected to a part of the driving voltage line **172** via a contact hole **65**.

[0098] The light emission control transistor **T6** includes the light emission control channel **131f**, a light emission control gate electrode **155f**, a light emission control source electrode **136f**, and a light emission control drain electrode **137f**. The light emission control gate electrode **155f**, which is a part of the light emission control line **153**, overlaps the light emission control channel **131f**, and the light emission control source electrode **136f** and the light emission control drain electrode **137f** are respectively formed adjacent to opposite sides of the light emission control channel **131f**. The light emission control drain electrode **137f** is connected to a third connecting member (or third connector) **179** via a contact hole **66**.

[0099] The bypass thin film transistor **T7** includes the bypass channel **131g**, a bypass gate electrode **155g**, a bypass source electrode **136g**, and a bypass drain electrode **137g**. The bypass gate electrode **155g**, which is a part of the bypass control line **158**, overlaps the bypass channel **131g**, and the bypass source electrode **136g** and the bypass drain electrode **137g** are respectively formed adjacent to opposite sides of the bypass channel **131g**. The bypass source electrode **136g** is connected to the third connecting member **179** via a contact hole **81**, and the bypass drain electrode **137g** is directly connected to the first initialization source electrode **136d1**.

[0100] One end of the driving channel **131a** of the driving transistor **T1** is connected to the switching drain electrode **137b** and the operation control drain electrode **137e**, and the other end of the driving channel **131a** is connected to the compensation source electrode **136c** and the light emission control source electrode **136f**.

[0101] The storage capacitor **Cst** includes a first storage electrode, a second storage electrode and an interlayer insulating layer **160** interposed therebetween. The second driving gate electrode **156** and the driving voltage line **172** overlap each other, with the interlayer insulating layer **160** interposed therebetween, and respectively form a first storage electrode and a second storage electrode that are opposite terminals of the storage capacitor **Cst**.

[0102] In this case, the second driving gate electrode **156**, which is an extension of a storage line **126**, corresponds to the first storage electrode, and a part of the driving voltage line **172** corresponds to the second storage electrode. Here, the interlayer insulating layer **160** serves as a dielectric material, and storage capacitance is determined by an amount of charge stored in the storage capacitor **Cst** and a voltage between the opposite electrodes **156** and **172**.

[0103] The second driving gate electrode **156** occupies a larger area than the first driving gate electrode **155a**, and covers the first driving gate electrode **155a**.

[0104] For example, the first driving gate electrode **155a** is positioned between the scan line **151** and the light emission control line **153** that extend in a horizontal direction, and is disposed on the same layer as the scan line **151** and the light emission control line **153**. In a high resolution structure, an area occupied by the first driving gate electrode **155a** decreases as an interval between the scan line **151** and the light emission control line **153** decreases.

[0105] On the contrary, the second driving gate electrode **156** is positioned on the scan line **151** and the light emission

control line 153, and thus in a high resolution structure, a large area can be secured even when the interval between the scan line 151 and the light emission control line 153 decreases.

[0106] In addition, the driving voltage line 172 positioned on the interlayer insulating layer 160 can secure a sufficient area even in a high resolution structure.

[0107] As described above, in the OLED display according to the current exemplary embodiment, the second driving gate electrode 156 having a larger size than the first driving gate electrode 155a is used as the first storage electrode, and the driving voltage line 172 is used as the second storage electrode, thereby increasing capacitance of the storage capacitor even in a high resolution structure.

[0108] The first driving gate electrode 155a and the second driving gate electrode 156 are electrically connected to one end of the first connecting member 174 via the contact hole 61.

[0109] The first connecting member 174 is substantially parallel to and disposed on the same layer as the data line 171, and the other end of the first connecting member 174 is connected to the second compensation drain electrode 137c2 of the second compensation transistor T3-2 and the second initialization drain electrode 137d2 of the second initialization transistor T4-2 via the contact hole 63. Accordingly, the first connecting member 174 couples the driving gate electrode 155a to both the second compensation drain electrode 137c2 of the second compensation transistor T3-2 and the second initialization drain electrode 137d2 of the second initialization transistor T4-2.

[0110] In this case, the storage capacitor Cst stores storage capacitance that corresponds to a difference between the driving voltage ELVDD transmitted to the second storage electrode via the driving voltage line 172 and the gate voltage Vg of the second driving gate electrode 156.

[0111] The third connecting member 179 is connected to the pixel electrode 191 via the contact hole 81, and the second connecting member 175 is connected to the initialization voltage line 192 via the contact hole 82.

[0112] A cross-sectional structure of an OLED display according to an exemplary embodiment will now be described in detail in accordance with a lamination order.

[0113] In this case, since an operation control transistor T5 has almost the same lamination structure as a light emission control transistor T6, a detailed description thereof will be omitted.

[0114] A buffer layer 120 is formed on a substrate 110. The substrate 110 can be formed as an insulating substrate that is formed of glass, quartz, ceramic, plastic, etc. The buffer layer 120 can serve to improve characteristics of a polysilicon semiconductor and to reduce stress applied to the substrate 110 by blocking impurities from the substrate 110 during a crystallization process for forming the polysilicon semiconductor.

[0115] A semiconductor 130 including a driving channel 131a, a switching channel 131b, a compensation channel 131c, an initialization channel 131d, an operation control channel 131e, a light emission control channel 131f, and a bypass channel 131g is formed on the buffer layer 120.

[0116] In the semiconductor 130, a driving source electrode 136a and a driving drain electrode 137a are formed at opposite sides of the driving channel 131a, and a switching source electrode 136b and a switching drain electrode 137b are formed at opposite sides of the switching channel 131b.

In addition, a first compensation source electrode 136c1 and a first compensation drain electrode 137c1 are formed at opposite sides of the first compensation channel 131d, a second compensation source electrode 136c2 and a second compensation drain electrode 137c2 are formed at opposite sides of the second compensation channel 131c2, a first initialization source electrode 136d1 and a first initialization drain electrode 137d1 are formed at opposite sides of the first initialization channel 131d1, and a second initialization source electrode 136d2 and a second initialization drain electrode 137d2 are formed at opposite sides of the second initialization channel 131d2. In addition, an operation control source electrode 136e and an operation control drain electrode 137e are formed at opposite sides of the operation control channel 131e, and a light emission control source electrode 136f and a light emission control drain electrode 137f are formed at opposite sides of the light emission control channel 131f. In addition, a bypass source electrode 136g and a bypass drain electrode 137g are formed at opposite sides of the bypass channel 131g.

[0117] A first gate insulating layer 141 is formed on the semiconductor 130 to cover it. A scan line 151 including a switching gate electrode 155b, a first compensation gate electrode 155c1, and a second compensation gate electrode 155c2, a previous scan line 152 including a first initialization gate electrode 155d1 and a second initialization gate electrode 155d2, a light emission control line 153 including an operation control gate electrode 155e and a light emission control gate electrode 155f, a bypass control line 158 including a bypass gate electrode 155g, and first gate wires 151, 152, 153, 158, 155a, 155b, 155c1, 155c2, 155d1, 155d2, 155e, and 155f including a first driving gate electrode 155a are formed on the first gate insulating layer 141.

[0118] A second gate insulating layer 142 is formed on the first gate wires 151, 152, 153, 158, 155a, 155b, 155c1, 155c2, 155d1, 155d2, 155e, and 155f and on the first gate insulating layer 141 to cover them. A contact hole 61 is formed in the second gate insulating layer 142. The first gate insulating layer 141 and the second gate insulating layer 142 can be formed of a silicon nitride (SiNx) or a silicon oxide (SiO2).

[0119] A storage line 126 arranged parallel to the scan line 151, and second gate wires 126 and 156, including the second driving gate electrode 156, which is an extension of the storage line 126, are formed on the second gate insulating layer 142.

[0120] An interlayer insulating layer 160 is formed on the second gate insulating layer 142 and on the second gate wires 126 and 156. The interlayer insulating layer 160 can be formed of a silicon nitride (SiNx) or a silicon oxide (SiO2).

[0121] Contact holes 61, 62, 63, 64, 65, 66, and 69 are formed in the interlayer insulating layer 160. Data wires 171, 172, 174, 175, and 179 including a data line 171, a driving voltage line 172, a first connecting member 174, a second data connecting member 175, and a third connecting member 179 are formed on the interlayer insulating layer 160.

[0122] The data line 171 is connected to the switching source electrode 136b via the contact hole 62 that is formed in the first gate insulating layer 141, the second gate insulating layer 142, and the interlayer insulating layer 160. One end of the first connecting member 174 is connected to the first driving gate electrode 155a and the second driving gate

electrode **156** via the contact hole **61** that is formed in the second gate insulating layer **142** and the interlayer insulating layer **160**. The other end of the first connecting member **174** is connected to the second compensation drain electrode **137c2** and the second initialization drain electrode **137d2** via the contact hole **63** formed in the first gate insulating layer **141**, the second gate insulating layer **142**, and the interlayer insulating layer **160**.

[0123] The second gate insulating layer **142** and the interlayer insulating layer **160** commonly include the contact hole **61**, and the first driving gate electrode **155a** and the second driving gate electrode **156** are electrically connected to one end of the first connecting member **174** via the contact hole **61**.

[0124] For example, the contact hole **61** partially exposes a surface of the first driving gate electrode **155a**, and exposes one end of the second driving gate electrode **156**. That is, one end of the first connecting member **174** can contact a part of a surface of the first driving gate electrode **155a** that is exposed by the contact hole **61**, and can contact one end of the second driving gate electrode **156**.

[0125] The quadrangular second connecting member **175** is connected to the first initialization source electrode **136d1** via the contact hole **64** formed in the first gate insulating layer **141**, the second gate insulating layer **142**, and the interlayer insulating layer **160**. In addition, the quadrangular third connecting member **179** is connected to the light emission control drain electrode **137f** via the contact hole **66** that is formed in the first gate insulating layer **141**, the second gate insulating layer **142**, and the interlayer insulating layer **160**.

[0126] A passivation layer **180** is formed on the data wires **171**, **172**, **174**, **175**, and **179** and on the interlayer insulating layer **160** to cover them. The passivation layer **180** can be formed as an organic layer.

[0127] A pixel electrode **191** and an initialization voltage line **192** are formed on the passivation layer **180**. The third connecting member **179** is connected to the pixel electrode **191** via a contact hole **81** that is formed in the passivation layer **180**, and the second connecting member **175** is connected to the initialization voltage line **192** via a contact hole **82** that is formed in the passivation layer **180**.

[0128] A pixel defining layer PDL **350** is formed on edges of the passivation layer **180**, the initialization voltage line **192**, and the pixel electrode **191** to cover them, and the pixel defining layer **350** has a pixel opening **351** that exposes the pixel electrode **191**. The pixel defining layer **350** can be formed of resins such as a polyacrylate resin and a polyimide resin or a silica-based inorganic material.

[0129] An organic emission layer **370** is formed on the exposed pixel electrode **191** by the pixel opening **351**, and a common electrode **270** is formed on the organic emission layer **370**. The common electrode **270** is also formed on the pixel defining layer **350**, and is formed across a plurality of pixels. As described above, an OLED including the pixel electrode **191**, the organic emission layer **370**, and the common electrode **270** is formed.

[0130] Herein, the pixel electrode **191** is an anode which is a hole injection electrode, and the common electrode **270** is a cathode which is an electron injection electrode. However, the exemplary embodiment according to the described technology is not necessarily limited thereto, and depending on a driving method of the OLED display, the pixel electrode **191** can be a cathode while the common electrode **270**

can be an anode. Holes and electrons from the pixel electrode **191** and the common electrode **270** are respectively injected into the organic emission layer **370**, and light is emitted when excitons generated by combining the injected holes and electrons fall from an excited state to a ground state.

[0131] The organic emission layer **370** is formed of a low molecular organic material or a polymer organic material such as poly(3,4-ethylenedioxythiophene) (PEDOT). In addition, the organic emission layer **370** can be formed of multiple layers, including the emission layer and one or more of a hole injection layer (HIL), a hole transporting layer (HTL), an electron transporting layer (ETL), and an electron injection layer (EIL). When including all of these layers, the hole injection layer is disposed on the pixel electrode **191**, which is the cathode, and the hole transporting layer, the emission layer, the electron transporting layer, and the electron injection layer are sequentially laminated thereon.

[0132] The organic emission layer **370** can include a red organic emission layer for emitting red light, a green organic emission layer for emitting green light, and a blue organic emission layer for emitting blue light, and the red organic emission layer, the green organic emission layer, and the blue organic emission layer are respectively formed on a red pixel, a green pixel, and a blue pixel, thereby realizing a color image.

[0133] Further, in the organic emission layer **370**, all of the red organic emission layer, the green organic emission layer, and the blue organic emission layer are laminated together on each of the red pixel, the green pixel, and the blue pixel, such that a red color filter, a green color filter, and a blue color filter are formed for each pixel, thereby realizing a color image. Alternatively, a white organic emission layer emitting white light is formed on all of the red pixel, the green pixel, and the blue pixel, and a red color filter, a green color filter, and a blue color filter are respectively formed for every pixel to implement a color image. When the color image is implemented by using the white organic emission layer and the color filter, a deposition mask for depositing the red organic emission layer, the green organic emission layer, and the blue organic emission layer on individual pixels, that is, the red pixel, the green pixel, and the blue pixel, is not required.

[0134] The white organic emission layer described in another exemplary embodiment can be formed to have a single organic emission layer, and can further include a configuration in which a plurality of organic emission layers are laminated to emit white light. For example, a configuration in which at least one yellow organic emission layer and at least one blue organic emission layer are combined to emit white light, a configuration in which at least one cyan organic emission layer and at least one red organic emission layer are combined to emit white light, and a configuration in which at least one magenta organic emission layer and at least one green organic emission layer are combined to emit white light can be further included.

[0135] An encapsulation member (not shown) for protecting the OLED can be formed on the common electrode **270**, and the encapsulation member can be sealed inside the substrate **110** by a sealant. The encapsulation member can be formed of a variety of materials such as glass, quartz, ceramic, plastic, and a metal. Meanwhile, without using a

sealant, an inorganic layer and an organic layer can be deposited on the common electrode 270 to form a thin film encapsulation layer.

[0136] While the inventive technology has been described in connection with what is presently considered to be practical exemplary embodiments, it is to be understood that the invention is not limited to the disclosed embodiments, but, on the contrary, is intended to cover various modifications and equivalent arrangements included within the spirit and scope of the appended claims.

What is claimed is:

1. An organic light-emitting diode (OLED) display comprising:

- a substrate;
- a semiconductor layer including a driving channel formed over the substrate;
- a first gate insulating layer at least partially covering the semiconductor layer;
- a first driving gate electrode formed over the first gate insulating layer and overlapping the driving channel in the depth dimension of the OLED display;
- a second gate insulating layer at least partially covering the first driving gate electrode;
- a second driving gate electrode formed over the second gate insulating layer and overlapping the first driving gate electrode in the depth dimension of the OLED display;
- an interlayer insulating layer at least partially covering the second driving gate electrode;
- a driving voltage line formed over the interlayer insulating layer and overlapping the second driving gate electrode in the depth dimension of the OLED display;
- and
- a connector formed over the interlayer insulating layer and connected to the first and second driving gate electrodes.

2. The OLED display of claim 1, wherein the interlayer insulating layer and the second gate insulating layer include a contact hole through which the connector passes to connect the first and second driving gate electrodes.

3. The OLED display of claim 2, wherein the contact hole is connected to one lateral end of the second driving gate electrode and a portion of a surface of the first driving gate electrode.

4. The OLED display of claim 1, further comprising a storage capacitor including:

- a first storage electrode formed over the second gate insulating layer and overlapping the driving channel in the depth dimension of the OLED display; and
- a second storage electrode overlapping the first storage electrode in the depth dimension of the OLED display, wherein the interlayer insulating layer is interposed between the first and second storage electrodes.

5. The OLED display of claim 4, wherein the first storage electrode is configured to function as the second driving gate electrode, and wherein the second storage electrode is configured to function as a portion of the driving voltage line.

6. The OLED display of claim 5, further comprising:
- a scan line formed on the same layer as the first driving gate electrode and configured to transfer a scan signal; and
 - a light emission control line formed on the same layer as the first driving gate electrode and extending parallel to

the scan line, wherein the light emission control line is configured to transfer a light emission control signal.

7. The OLED display of claim 6, wherein the first driving gate electrode is positioned between the scan line and the light emission control line.

8. The OLED display of claim 4, wherein the driving voltage line is configured to transfer a driving voltage.

9. The OLED display of claim 4, wherein each of the first and second driving gate electrode is configured to receive a gate voltage via the connector.

10. The OLED display of claim 4, wherein the second driving gate electrode has an area larger than that of the first driving gate electrode.

11. The OLED display of claim 1, wherein the semiconductor layer further includes a switching channel, a compensation channel, an initialization channel, an operation control channel, a light emission control channel, and a bypass channel.

12. The OLED display of claim 1, further comprising a passivation layer covering the interlayer insulating layer, wherein the OLED includes a pixel electrode formed over the passivation layer, an organic emission layer formed over the pixel electrode, and a common electrode formed over the organic emission layer.

13. An organic light-emitting diode (OLED) display comprising:

- a first gate insulating layer;
- a first driving gate electrode formed over the first gate insulating layer;
- a second gate insulating layer formed over the first driving gate electrode;
- a second driving gate electrode formed over the second gate insulating layer;
- an interlayer insulating layer formed over the second driving gate electrode and having a contact hole formed therein; and
- a connector passing through the contact hole and connecting the first and second driving gate electrodes so as to form a conductive path between the electrodes.

14. The OLED display of claim 13, wherein the connector extends to and contacts the interlayer insulating layer.

15. The OLED display of claim 14, further comprising a driving voltage line configured to transfer a driving voltage, wherein the second driving gate electrode and the driving voltage line form a storage capacitor.

16. The OLED display of claim 13, wherein the first driving gate electrode has a width that is larger than that of the second driving gate electrode.

17. The OLED display of claim 13, wherein a bottom surface of the contact hole is connected to a top surface of the first driving gate electrode.

18. The OLED display of claim 17, wherein the second driving gate electrode has an end that penetrates a side surface of the contact hole.

19. The OLED display of claim 18, further comprising a storage line formed on the second gate insulating layer, wherein the second driving gate electrode is an extension of the storage line.

20. The OLED display of claim 14, wherein the interlayer insulating layer is thicker than a combined thickness of the first and second driving gate electrodes.

* * * * *

专利名称(译)	有机发光二极管显示器		
公开(公告)号	US20170040407A1	公开(公告)日	2017-02-09
申请号	US15/228974	申请日	2016-08-04
[标]申请(专利权)人(译)	三星显示有限公司		
申请(专利权)人(译)	三星DISPLAY CO., LTD.		
当前申请(专利权)人(译)	三星DISPLAY CO., LTD.		
[标]发明人	SHIN HWANG SUP JUNG JIN GOO		
发明人	SHIN, HWANG SUP JUNG, JIN GOO		
IPC分类号	H01L27/32 H01L51/52		
CPC分类号	H01L27/3276 H01L27/3262 H01L51/5203 H01L27/3258 H01L27/3265 G09G3/32 G09G3/3233 G09G2300/0426 G09G2300/0819 G09G2300/0842 G09G2300/0861 G09G2320/0238 H01L27/3248		
优先权	1020150111262 2015-08-06 KR		
其他公开文献	US10002916		
外部链接	Espacenet USPTO		

摘要(译)

公开了一种有机发光二极管显示器。在一个方面，显示器包括：半导体层，包括驱动沟道；至少部分地覆盖半导体层的第一栅极绝缘层；以及形成在第一栅极绝缘层上并与驱动重叠的第一驱动栅电极。第二栅极绝缘层至少部分地覆盖第一驱动栅电极。显示器还包括形成在第二栅极绝缘层上并与第一驱动栅电极重叠的第二驱动栅电极，至少部分地覆盖第二驱动栅电极的层间绝缘层，形成在层间绝缘层上的驱动电压线，第二驱动栅电极，以及形成在层间绝缘层上并且连接到第一和第二驱动栅电极的连接部。

